



CGA CONNECTIONS

CGA 接头

COMPANY INTRODUCTION

公司简介

Solutions for Life



公司简介

捷锐企业（上海）有限公司，研发制造高洁净之集中供气系统及流体压力控制相关零组件、系统设备、仪器仪表、焊割器具等，并设有技术支持部为客户提供技术咨询、设计、工程安装及维修等服务。产品主要应用在半导体、气体、化工、生物科技、核电、航天、食品等行业。

质量保证

品质保证是捷锐营运流程不可分割的部分，从接单、制造到出货，我们采用了ISO 9001质量系统及全员品质管理体系(TQM)，确保产品质量。捷锐产品符合现行标准，包括：UL, ANSI, SEMI, NFPA, ASME, ASTM, API, CE, 3C等标准与认证。

深耕企业文化，强调团队合作

捷锐每一位新进人员前两个月必须接受相关知识与企业文化培训，例如：公司领导以身作则、诚实、积极、拒绝傲慢与惰性；所有员工必须具有工作热忱，擅于沟通，无界限互动，合作促进，倾力解决，充满自信，不断学习，追求理想与愿景，使全体员工拥有捷锐人独特的价值观和行为规范。

具备多功能制造技术

捷锐培育了大批的工程技术人员，从零件、组件到系统设备，生产一贯作业。厂区具备夹治具制造、精密加工机械、电解抛光、自动精密焊接、多功能实验室、无尘室、高精度检测仪器、仪表等设施与设备。

先进的检验设备

捷锐配置了大量的检测设备，如：三坐标投影仪、减压器全流量测试装置、氧浓度测试仪、数显微小硬度计、金相显微镜、弹簧测试仪、氦气测漏仪、粗糙度测试仪等。

捷锐企业（上海）有限公司生产的CGA接头采用优质黄铜和不锈钢材料制造，可用于高纯气体，特种气体及医用气体。

FSR接管



NPT接管



自动焊接管



FSR接管



接瓶架



订购指南 Ordering Information

SS - 材料 Material	CGA330 - 标准 Standard	3 - 长度 length	NT2 螺纹 Nipple Scre
B: 黄铜	CGA330: CGA V1 No.330	1.5: 1.5"	Null: 1/4" NPT Male
BP: 黄铜电镀	BS03: BS341 No.3	2: 2"	NT2: 1/8" NPT Male
S3: 303 或 304 不锈钢	DIN05: DIN477 No.5	3: 3"	NT6: 3/8" NPT Male
SS: 316 不锈钢	TW: 1/4" Tube Weld
SL: 316L 不锈钢			VM: 1/4" FSR Male
		

CGA接头详细参数见标准《CGA V-1—2005》
更多规格请联系捷锐公司

CGA CONNECTIONS

CGA 接头

Solutions for Life

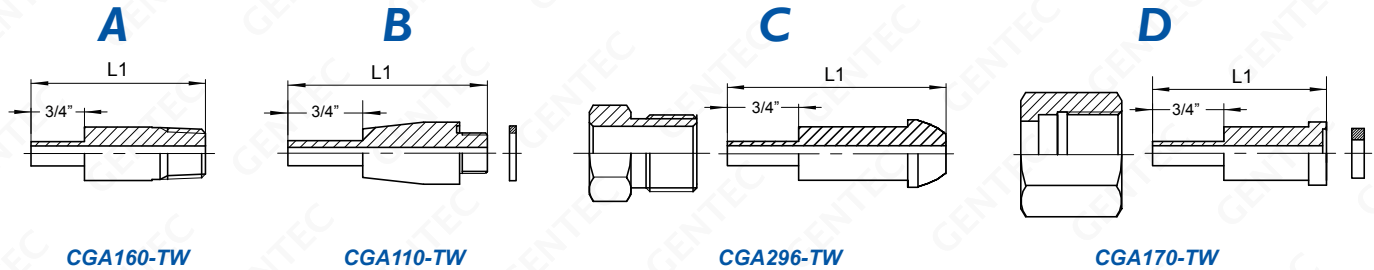

接头标准号 Standard No.	接头型号 Model No.	类型 Type	材料 Material	接管长度 L1 Nipple Length	进口连接(钢瓶端) Nut Screw	出口连接 Outlet Connection	垫片 Washer	适用气体, 压力 Gases, Pressure
CGA 110*	SS-CGA110-2	B	SS 316	2"	0.3125-32UNEF-2A-RH	1/4" NPT Male	WS-NL-CGA110 (Nylon)	适用气体: 所有气体 最高工作压力: 3000 psig (20 680 kPa)
	SS-CGA110-2-TW		SS 316			1/4" Tube Weld		
	SS-CGA110-2-VM		SS 316			1/4" FSR Male		
	B-CGA110-2		黄铜			1/4" NPT Male		
	BP-CGA110-2		黄铜电镀			1/4" NPT Male		
CGA 160*	SS-CGA160-1.5-NT2	A	SS 316	1-1/2"	1/8-27NGT-RH	1/8" NPT Male	/	适用气体: COCl2 最高工作压力: 500 psig (3450 kPa)
	SS-CGA160-1.5-TW		SS 316			1/4" Tube Weld		
	SS-CGA160-1.5-VM		SS 316			1/4" FSR Male		
	B-CGA160-1.5-NT2		黄铜			1/8" NPT Male		
	BP-CGA160-1.5-NT2		黄铜电镀			1/8" NPT Male		
CGA 170	SS-CGA170-1.5-NT2	D	SS 316	1-1/2"	0.5625-18UNF-2B-RH	1/8" NPT Male	WS-NL-CGA170 (Nylon)	适用气体: 非腐蚀性气体 最高工作压力: 3000 psig (20 680 kPa)
	SS-CGA170-1.5-TW		SS 316			1/4" Tube Weld		
	SS-CGA170-1.5-VM		SS 316			1/4" FSR Male		
	B-CGA170-1.5-NT2		黄铜			1/8" NPT Male		
	BP-CGA170-1.5-NT2		黄铜电镀			1/8" NPT Male		
CGA 180	SS-CGA180-1.5-NT2	D	SS 316	1-1/2"	0.5625-18UNF-2B-RH	1/8" NPT Male	WS-NL-CGA180 (Nylon)	适用气体: 所有气体 最高工作压力: 3000 psig (20 680 kPa)
	SS-CGA180-1.5-TW		SS 316			1/4" Tube Weld		
	SS-CGA180-1.5-VM		SS 316			1/4" FSR Male		
	B-CGA180-1.5-NT2		黄铜			1/8" NPT Male		
	BP-CGA180-1.5-NT2		黄铜电镀			1/8" NPT Male		
CGA 200	SS-CGA200-1.5-NT2	C	SS 316	1-1/8"	0.625-20NGO-RH	1/8" NPT Male	/	适用气体: C2H2 最高工作压力: 500 psig (3450 kPa)
	SS-CGA200-1.5-TW		SS 316			1/4" Tube Weld		
	SS-CGA200-1.5-VM		SS 316			1/4" FSR Male		
	B-CGA200-1.5-NT2		黄铜			1/8" NPT Male		
	BP-CGA200-1.5-NT2		黄铜电镀			1/8" NPT Male		
CGA 240*	SS-CGA240-3-NT6	A	SS 316	3"	3/8-18NGT-RH	3/8" NPT Male	/	适用气体: NH3 最高工作压力: 500 psig (3450 kPa)
	SS-CGA240-3-TW		SS 316			1/4" Tube Weld		
	SS-CGA240-3-VM		SS 316			1/4" FSR Male		
	B-CGA240-3-NT6		黄铜			3/8" NPT Male		
	BP-CGA240-3-NT6		黄铜电镀			3/8" NPT Male		
CGA 280*	SS-CGA280-2.5	C	SS 316	2-1/2"	0.750-14NGO-RH	1/4" NPT Male	/	适用气体: 医用呼吸混合气体 最高工作压力: 3000 psig (20 680 kPa)
	SS-CGA280-2.5-TW		SS 316			1/4" Tube Weld		
	SS-CGA280-2.5-VM		SS 316			1/4" FSR Male		
	B-CGA280-2.5		黄铜			1/4" NPT Male		
	BP-CGA280-2.5		黄铜电镀			1/4" NPT Male		
CGA 290*	SS-CGA290-2.5	C	SS 316	2-1/2"	0.750-14NGO-RH	1/4" NPT Male	/	适用气体: C5H12BrN, C2H3Cl, CH2 最高工作压力: 500 psig (3450 kPa)
	SS-CGA290-2.5-TW		SS 316			1/4" Tube Weld		
	SS-CGA290-2.5-VM		SS 316			1/4" FSR Male		
	B-CGA290-2.5		黄铜			1/4" NPT Male		
	BP-CGA290-2.5		黄铜电镀			1/4" NPT Male		

*未备库存

详细参数见标准《CGA V-1—2005》

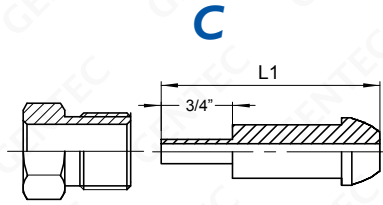
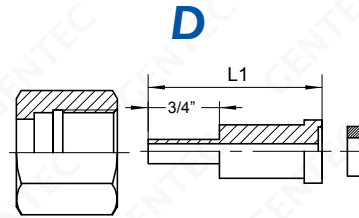
CGA296-TW

CGA170-TW

接头标准号 Standard No.	接头型号 Model No.	类型 Type	材料 Material	接管长度 L1 Nipple Length	进口连接(钢瓶端) Nut Screw	出口连接 Outlet Connection	垫片 Washer	适用气体, 压力 Gases, Pressure
CGA 296*	SS-CGA296-3	C	SS 316	3"	0.803-14UNS-2A-RH	1/4" NPT Male	/	适用气体: 工业氧化混合物 最高工作压力: 3000 psig (20 680 kPa)
	SS-CGA296-3-TW		SS 316			1/4" Tube Weld		
	SS-CGA296-3-VM		SS 316			1/4" FSR Male		
	B-CGA296-3		黄铜			1/4" NPT Male		
	BP-CGA296-3		黄铜电镀			1/4" NPT Male		
CGA 300	SS-CGA300-2.5	C	SS 316	2-1/2"	0.830-14NGO-RH	1/4" NPT Male	/	适用气体: C ₂ H ₆ Cl 最高工作压力: 500 psig (3450 kPa)
	SS-CGA300-2.5-TW		SS 316			1/4" Tube Weld		
	SS-CGA300-2.5-VM		SS 316			1/4" FSR Male		
	B-CGA300-2.5		黄铜			1/4" NPT Male		
	BP-CGA300-2.5		黄铜电镀			1/4" NPT Male		
CGA 320	SS-CGA320-2	D	SS 316	2"	0.830-14NGO-RH	1/4" NPT Male	WS-NL-CGA320 (Nylon)	适用气体: CO ₂ 最高工作压力: 3000 psig (20 680 kPa)
	SS-CGA320-2-TW		SS 316			1/4" Tube Weld		
	SS-CGA320-2-VM		SS 316			1/4" FSR Male		
	B-CGA320-2		黄铜			1/4" NPT Male		
	BP-CGA320-2		黄铜电镀			1/4" NPT Male		
CGA 326	SS-CGA326-2.5	C	SS 316	2-1/2"	0.830-14NGO-RH	1/4" NPT Male	/	适用气体: N ₂ O 最高工作压力: 3000 psig (20 680 kPa)
	SS-CGA326-2.5-TW		SS 316			1/4" Tube Weld		
	SS-CGA326-2.5-VM		SS 316			1/4" FSR Male		
	B-CGA326-2.5		黄铜			1/4" NPT Male		
	BP-CGA326-2.5		黄铜电镀			1/4" NPT Male		
CGA 330	SS-CGA330-2	D	SS 316	2"	0.830-14NGO-RH	1/4" NPT Male	WS-NL-CGA320 (Nylon)	适用气体: HCl, HI, HS, PF ₅ , SiF ₄ , etc. 最高工作压力: 3000 psig (20 680 kPa)
	SS-CGA330-2-TW		SS 316			1/4" Tube Weld		
	SS-CGA330-2-VM		SS 316			1/4" FSR Male		
	B-CGA330-2		黄铜			1/4" NPT Male		
	BP-CGA330-2		黄铜电镀			1/4" NPT Male		
CGA 346	SS-CGA346-2.5	C	SS 316	2-1/2"	0.830-14NGO-RH	1/4" NPT Male	/	适用气体: Air 最高工作压力: 3000 psig (20 680 kPa)
	SS-CGA346-2.5-TW		SS 316			1/4" Tube Weld		
	SS-CGA346-2.5-VM		SS 316			1/4" FSR Male		
	B-CGA346-2.5		黄铜			1/4" NPT Male		
	BP-CGA346-2.5		黄铜电镀			1/4" NPT Male		
CGA 347	SS-CGA347-3	C	SS 316	3"	0.830-14NGO-RH	1/4" NPT Male	/	适用气体: Air 最高工作压力: 5500 psig (37 900 kPa)
	SS-CGA347-3-TW		SS 316			1/4" Tube Weld		
	SS-CGA347-3-VM		SS 316			1/4" FSR Male		
	B-CGA347-3		黄铜			1/4" NPT Male		
	BP-CGA347-3		黄铜电镀			1/4" NPT Male		
CGA 350	SS-CGA350-2.5	C	SS 316	2-1/2"	0.830-14NGO-LH	1/4" NPT Male	/	适用气体: H, CO, 天然气, CH ₄ , C ₂ H ₆ , etc 最高工作压力: 3000 psig (20 680 kPa)
	SS-CGA350-2.5-TW		SS 316			1/4" Tube Weld		
	SS-CGA350-2.5-VM		SS 316			1/4" FSR Male		
	B-CGA350-2.5		黄铜			1/4" NPT Male		
	BP-CGA350-2.5		黄铜电镀			1/4" NPT Male		

*未备库存

详细参数见标准《CGA V-1—2005》

CGA CONNECTIONS

CGA 接头

Solutions for Life

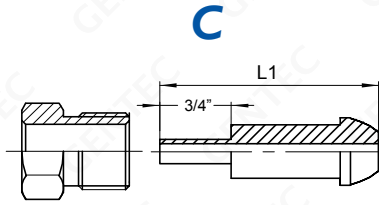

CGA296-TW

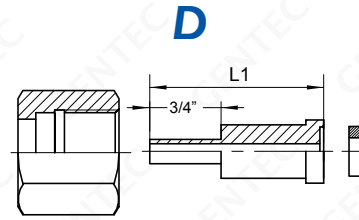

CGA170-TW

接头标准号 Standard No.	接头型号 Model No.	类型 Type	材料 Material	接管长度 L1 Nipple Length	进口连接(钢瓶端) Nut Screw	出口连接 Outlet Connection	垫片 Washer	适用气体, 压力 Gases, Pressure
CGA 410*	SS-CGA410-2.5	C	SS 316	2-1/2"	0.855-14NGO-LH	1/4" NPT Male	/	适用气体: C2H2 最高工作压力: 500 psig (3450 kPa)
	SS-CGA410-2.5-TW		SS 316			1/4" Tube Weld		
	SS-CGA410-2.5-VM		SS 316			1/4" FSR Male		
	B-CGA410-2.5		黄铜			1/4" NPT Male		
	BP-CGA410-2.5		黄铜电镀			1/4" NPT Male		
CGA 415*	SS-CGA415-2	D	SS 316	2"	0.855-14NGO-LH	1/4" NPT Male	WS-NL-CGA415 (Nylon)	适用气体: C2H2 最高工作压力: 500 psig (3450 kPa)
	SS-CGA415-2-TW		SS 316			1/4" Tube Weld		
	SS-CGA415-2-VM		SS 316			1/4" FSR Male		
	B-CGA415-2		黄铜			1/4" NPT Male		
	BP-CGA415-2		黄铜电镀			1/4" NPT Male		
CGA 500	SS-CGA500-3	C	SS 316	3"	0.880-14NGO-RH	1/4" NPT Male	/	适用气体: 混合气体 最高工作压力: 3000 psig (20 680 kPa)
	SS-CGA500-3-TW		SS 316			1/4" Tube Weld		
	SS-CGA500-3-VM		SS 316			1/4" FSR Male		
	B-CGA500-3		黄铜			1/4" NPT Male		
	BP-CGA500-3		黄铜电镀			1/4" NPT Male		
CGA 510	SS-CGA510-3	C	SS 316	3"	0.880-14NGO-LH	1/4" NPT Male	/	适用气体: C4H10Zn, CH3Cl, C3H4, etc 最高工作压力: 500 psig (3450 kPa)
	SS-CGA510-3-TW		SS 316			1/4" Tube Weld		
	SS-CGA510-3-VM		SS 316			1/4" FSR Male		
	B-CGA510-3		黄铜			1/4" NPT Male		
	BP-CGA510-3		黄铜电镀			1/4" NPT Male		
CGA 520	SS-CGA520-2.5	C	SS 316	2"	0.899-18NGO-RH	1/4" NPT Male	/	适用气体: C2H2 最高工作压力: 500 psig (3450 kPa)
	SS-CGA520-2.5-TW		SS 316			1/4" Tube Weld		
	SS-CGA520-2.5-VM		SS 316			1/4" FSR Male		
	B-CGA520-2.5		黄铜			1/4" NPT Male		
	BP-CGA520-2.5		黄铜电镀			1/4" NPT Male		
CGA 540	SS-CGA540-2.5	C	SS 316	2-1/2"	0.908-14NGO-RH	1/4" NPT Male	/	适用气体: O ₂ 最高工作压力: 3000 psig (20 680 kPa)
	SS-CGA540-2.5-TW		SS 316			1/4" Tube Weld		
	SS-CGA540-2.5-VM		SS 316			1/4" FSR Male		
	B-CGA540-2.5		黄铜			1/4" NPT Male		
	BP-CGA540-2.5		黄铜电镀			1/4" NPT Male		
CGA 555*	SS-CGA555-2.5	C	SS 316	2-1/2"	0.908-14NGO-LH	1/4" NPT Male	/	适用气体: C4H10, C3H8 最高工作压力: 3000 psig (20 680 kPa)
	SS-CGA555-2.5-TW		SS 316			1/4" Tube Weld		
	SS-CGA555-2.5-VM		SS 316			1/4" FSR Male		
	B-CGA555-2.5		黄铜			1/4" NPT Male		
	BP-CGA555-2.5		黄铜电镀			1/4" NPT Male		
CGA 577	SS-CGA577-2.5	C	SS 316	2-1/2"	0.965-14NGO-RH	1/4" NPT Male	/	适用气体: O ₂ 最高工作压力: 4000 psig (27 580 kPa)
	SS-CGA577-2.5-TW		SS 316			1/4" Tube Weld		
	SS-CGA577-2.5-VM		SS 316			1/4" FSR Male		
	B-CGA577-2.5		黄铜			1/4" NPT Male		
	BP-CGA577-2.5		黄铜电镀			1/4" NPT Male		

*未备库存

详细参数见标准《CGA V-1—2005》

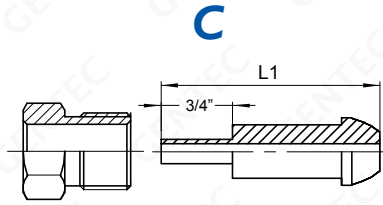
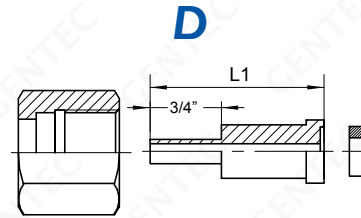
CGA296-TW

CGA170-TW

接头标准号 Standard No.	接头型号 Model No.	类型 Type	材料 Material	接管长度 L1 Nipple Length	进口连接(钢瓶端) Nut Screw	出口连接 Outlet Connection	垫片 Washer	适用气体, 压力 Gases, Pressure
CGA 580	SS-CGA580-3	C	SS 316	3"	0.960-14NGO-RH	1/4" NPT Male	/	适用气体: Ar, N2, He, Kr, Ne, Xe, CF4, etc. 最高工作压力: 3000 psig (20 680 kPa)
	SS-CGA580-3-TW		SS 316			1/4" Tube Weld		
	SS-CGA580-3-VM		SS 316			1/4" FSR Male		
	B-CGA580-3		黄铜			1/4" NPT Male		
	BP-CGA580-3		黄铜电镀			1/4" NPT Male		
CGA 590	SS-CGA590-3	C	SS 316	3"	0.960-14NGO-LH	1/4" NPT Male	/	适用气体: SF6 最高工作压力: 3000 psig (20 680 kPa)
	SS-CGA590-3-TW		SS 316			1/4" Tube Weld		
	SS-CGA590-3-VM		SS 316			1/4" FSR Male		
	B-CGA590-3		黄铜			1/4" NPT Male		
	BP-CGA590-3		黄铜电镀			1/4" NPT Male		
CGA 620*	SS-CGA620-3	C	SS 316	3"	1.035-14NGO-RH	1/4" NPT Male	/	最高工作压力: 5500 psig (37 900 kPa)
	SS-CGA620-3-TW		SS 316			1/4" Tube Weld		
	SS-CGA620-3-VM		SS 316			1/4" FSR Male		
	B-CGA620-3		黄铜			1/4" NPT Male		
	BP-CGA620-3		黄铜电镀			1/4" NPT Male		
CGA 660	SS-CGA660-2	D	SS 316	2"	0.830-14NGO-RH	1/4" NPT Male	WS-NL-CGA660 (Nylon)	适用气体: NO, NO2, N2O3, C4H8Cl2S, COCl2, etc. 最高工作压力: 3000 psig (20 680 kPa)
	SS-CGA660-2-TW		SS 316			1/4" Tube Weld		
	SS-CGA660-2-VM		SS 316			1/4" FSR Male		
	B-CGA660-2		黄铜			1/4" NPT Male		
	BP-CGA660-2		黄铜电镀			1/4" NPT Male		
CGA 668*	SS-CGA668-2.5	D	SS 316	2-1/2"	1.035-14NGO-RH	1/4" NPT Male	WS-NL-CGA668 (Nylon)	适用气体: HFC125, SO2, HFP, CHCLF2, HCFC-124, etc. 最高工作压力: 500 psig (3450 kPa)
	SS-CGA668-2.5-TW		SS 316			1/4" Tube Weld		
	SS-CGA668-2.5-VM		SS 316			1/4" FSR Male		
	B-CGA668-2.5		黄铜			1/4" NPT Male		
	BP-CGA668-2.5		黄铜电镀			1/4" NPT Male		
CGA 670*	SS-CGA670-2	D	SS 316	2"	1.035-14NGO-LH	1/4" NPT Male	WS-NL-CGA660 (Nylon)	适用气体: BrF5, HF, BrF3, IF5, ClF5, etc. 最高工作压力: 3000 psig (20 680 kPa)
	SS-CGA670-2-TW		SS 316			1/4" Tube Weld		
	SS-CGA670-2-VM		SS 316			1/4" FSR Male		
	B-CGA670-2		黄铜			1/4" NPT Male		
	BP-CGA670-2		黄铜电镀			1/4" NPT Male		
CGA 677	SS-CGA677-2.5	C	SS 316	2-1/2"	1.035-14NGO-LH	1/4" NPT Male	/	适用气体: Ar, Ne, He, N2, Kr, Xe 最高工作压力: 7500 psig (38 000 kPa)
	SS-CGA677-2.5-TW		SS 316			1/4" Tube Weld		
	SS-CGA677-2.5-VM		SS 316			1/4" FSR Male		
	B-CGA677-2.5		黄铜			1/4" NPT Male		
	BP-CGA677-2.5		黄铜电镀			1/4" NPT Male		
CGA678*	SS-CGA678-2.5	D	SS 316	2-1/2"	1.035-14NGO-LH	1/4" NPT Male	WS-NL-CGA668 (Nylon)	适用气体: H2Cl2Si 最高工作压力: 500 psig (3450 kPa)
	SS-CGA678-2.5-TW		SS 316			1/4" Tube Weld		
	SS-CGA678-2.5-VM		SS 316			1/4" FSR Male		
	B-CGA678-2.5		黄铜			1/4" NPT Male		
	BP-CGA678-2.5		黄铜电镀			1/4" NPT Male		

*未备库存

详细参数见标准《CGA V-1—2005》

CGA CONNECTIONS

CGA 接头

Solutions for Life

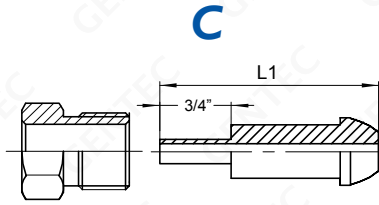

CGA296-TW

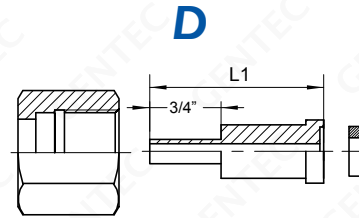

CGA170-TW

接头标准号 Standard No.	接头型号 Model No.	类型 Type	材料 Material	接管长度 L1 Nipple Length	进口连接(钢瓶端) Nut Screw	出口连接 Outlet Connection	垫片 Washer	适用气体, 压力 Gases, Pressure
CGA 679*	SS-CGA679-2.5	C	SS 316	2-1/2"	1.035-14NGO-LH	1/4" NPT Male	WS-NL-CGA679 (Nylon)	适用气体: F, PTFE, OF2, C4H10FO2P 最高工作压力: 500 psig (3450 kPa)
	SS-CGA679-2.5-TW		SS 316			1/4" Tube Weld		
	SS-CGA679-2.5-VM		SS 316			1/4" FSR Male		
	B-CGA679-2.5		黄铜			1/4" NPT Male		
	BP-CGA679-2.5		黄铜电镀			1/4" NPT Male		
CGA 680	SS-CGA680-3	C	SS 316	3"	1.040-14NGO-RH	1/4" NPT Male	/	适用气体: Ar, Kr, N2, He, Ne, Xe 最高工作压力: 5500 psig (37 900 kPa)
	SS-CGA680-3-TW		SS 316			1/4" Tube Weld		
	SS-CGA680-3-VM		SS 316			1/4" FSR Male		
	B-CGA680-3		黄铜			1/4" NPT Male		
	BP-CGA680-3		黄铜电镀			1/4" NPT Male		
CGA 695*	SS-CGA695-3	C	SS 316	3"	1.040-14NGO-LH	1/4" NPT Male	/	适用气体: 易燃气体 (H, CH4, 天然气) 最高工作压力: 5500 psig (37 900 kPa)
	SS-CGA695-3-TW		SS 316			1/4" Tube Weld		
	SS-CGA695-3-VM		SS 316			1/4" FSR Male		
	B-CGA695-3		黄铜			1/4" NPT Male		
	BP-CGA695-3		黄铜电镀			1/4" NPT Male		
CGA 701*	SS-CGA701-2.5	C	SS 316	2-1/2"	1.108-14NGO-RH	1/4" NPT Male	/	适用气体: O2 最高工作压力: 5500 psig (37 900 kPa)
	SS-CGA701-2.5-TW		SS 316			1/4" Tube Weld		
	SS-CGA701-2.5-VM		SS 316			1/4" FSR Male		
	B-CGA701-2.5		黄铜			1/4" NPT Male		
	BP-CGA701-2.5		黄铜电镀			1/4" NPT Male		
CGA 702*	SS-CGA702-3	C	SS 316	3"	1.120-14NGO-RH	1/4" NPT Male	/	适用气体: Air 最高工作压力: 7500 psig (51 700 kPa)
	SS-CGA702-3-TW		SS 316			1/4" Tube Weld		
	SS-CGA702-3-VM		SS 316			1/4" FSR Male		
	B-CGA702-3		黄铜			1/4" NPT Male		
	BP-CGA702-3		黄铜电镀			1/4" NPT Male		
CGA 703*	SS-CGA703-3	C	SS 316	3"	1.120-14NGO-LH	1/4" NPT Male	/	适用气体: 易燃气体 (H, CH4, 天然气) 最高工作压力: 7500 psig (51 700 kPa)
	SS-CGA703-3-TW		SS 316			1/4" Tube Weld		
	SS-CGA703-3-VM		SS 316			1/4" FSR Male		
	B-CGA703-3		黄铜			1/4" NPT Male		
	BP-CGA703-3		黄铜电镀			1/4" NPT Male		
CGA705*	SS-CGA705-2	D	SS 316	2"	1.125-14UNS-2B-RH	1/4" NPT Male	WS-NL-CGA705 (Nylon)	适用气体: NH3, CH3NH2, C2H7N, C3H9N, C2H7N 最高工作压力: 3000 psig (20 680 kPa)
	SS-CGA705-2-TW		SS 316			1/4" Tube Weld		
	SS-CGA705-2-VM		SS 316			1/4" FSR Male		
	B-CGA705-2		黄铜			1/4" NPT Male		
	BP-CGA705-2		黄铜电镀			1/4" NPT Male		
CGA 750*	SS-CGA755-2.5	D	SS 316	2-1/2"	1.125-14UNS-2B-LH	1/4" NPT Male	WS-NL-CGA750 (Nylon)	适用气体: CF2, C2N2, CNCl, CH3CH2F, etc. 最高工作压力: 3000 psig (20 680 kPa)
	SS-CGA755-2.5-TW		SS 316			1/4" Tube Weld		
	SS-CGA755-2.5-VM		SS 316			1/4" FSR Male		
	B-CGA755-2.5		黄铜			1/4" NPT Male		
	BP-CGA755-2.5		黄铜电镀			1/4" NPT Male		

*未备库存

详细参数见标准《CGA V-1—2005》

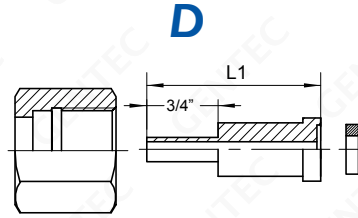

CGA170-TW

接头标准号 Standard No.	接头型号 Model No.	类型 Type	材料 Material	接管长度 L1 Nipple Length	进口连接 (钢瓶端) Nut Screw	出口连接 Outlet Connection	垫片 Washer	适用气体, 压力 Gases, Pressure
CGA 755*	SS-CGA755-2.5	D	SS 316	2-1/2"	1.125-14UNS-2B-LH	1/4" NPT Male	WS-NL-CGA668 (Nylon)	最高工作压力： 3000 psig (20 680 kPa)
	SS-CGA755-2.5-TW		SS 316			1/4" Tube Weld		
	SS-CGA755-2.5-VM		SS 316			1/4" FSR Male		
	B-CGA755-2.5		黄铜			1/4" NPT Male		
	BP-CGA755-2.5		黄铜电镀			1/4" NPT Male		

*未备库存

详细参数见标准《CGA V-1—2005》

UHP CGA CONNECTIONS

UHP CGA 接头

Solutions for Life

UHP CGA系列为EP级产品，接头采用优质不锈钢制造，可用于高纯气体、特种气体及医用气体。

自动焊接管



NPT 螺纹



FSR 螺纹



特点:

- * 螺母采用 303 材料
- * 垫片采用 Nickel 材料
- * 进气管、堵帽采用316L材料
- * 进气管连接方式有Auto Tube Weld, NPT Male, FSR Male三种可选

UHP CGA CONNECTIONS

Solutions for Life

UHP CGA 接头



接头标准号 Standard No.	接头型号 Model No.	接管长度 L1 Nipple Length	螺帽长度 L2 Nut Length	进口连接(钢瓶端) Nut Screw	出口连接 Outlet Connection	垫片 Washer	堵帽 Cap	适用气体, 压力 Gases, Pressure
CGA 632	SS-CGA632-3	3"	1-1/8"	1.030-14NGO-RH	1/4" NPT Male	NI-G-63	/	适用气体: AsH ₃ , GeH ₄ , SiH ₄ , B ₂ H ₆ , H ₂ Se, C ₃ H ₁₀ Si, Si ₂ H ₆ , PH ₃
	SS-CGA632-2.5-TW	2.5"			1/4" Tube Weld			
	SS-CGA632-3-VM	3"			1/4" FSR Male			
	SS-CGA632-3-SET	3"			1/4" NPT Male			
	SS-CGA632-2.5-TW-SET	2.5"			1/4" Tube Weld			
	SS-CGA632-3-VM-SET	3"			1/4" FSR Male			
CGA 634	SS-CGA634-3	3"	1-1/8"	1.030-14NGO-RH	1/4" NPT Male	NI-G-63	/	适用气体: BCl ₃ , HBr, HCl
	SS-CGA634-2.5-TW	2.5"			1/4" Tube Weld			
	SS-CGA634-3-VM	3"			1/4" FSR Male			
	SS-CGA634-3-SET	3"			1/4" NPT Male			
	SS-CGA634-2.5-TW-SET	2.5"			1/4" Tube Weld			
	SS-CGA634-3-VM-SET	3"			1/4" FSR Male			
CGA 636	SS-CGA636-3	3"	1-1/8"	1.030-14NGO-RH	1/4" NPT Male	NI-G-63	/	适用气体: SiH ₂ Cl ₂ , SiCl ₄ , HCl ₃ Si
	SS-CGA636-2.5-TW	2.5"			1/4" Tube Weld			
	SS-CGA636-3-VM	3"			1/4" FSR Male			
	SS-CGA636-3-SET	3"			1/4" NPT Male			
	SS-CGA636-2.5-TW-SET	2.5"			1/4" Tube Weld			
	SS-CGA636-3-VM-SET	3"			1/4" FSR Male			
CGA 638	SS-CGA638-3	3"	1-1/8"	1.030-14NGO-RH	1/4" NPT Male	NI-G-63	/	适用气体: SiH ₂ Cl ₂ , SiCl ₄
	SS-CGA638-2.5-TW	2.5"			1/4" Tube Weld			
	SS-CGA638-3-VM	3"			1/4" FSR Male			
	SS-CGA638-3-SET	3"			1/4" NPT Male			
	SS-CGA638-2.5-TW-SET	2.5"			1/4" Tube Weld			
	SS-CGA638-3-VM-SET	3"			1/4" FSR Male			
CGA 640	SS-CGA640-3	3"	1-1/8"	1.030-14NGO-RH	1/4" NPT Male	NI-G-63	/	适用气体: NF ₃
	SS-CGA640-2.5-TW	2.5"			1/4" Tube Weld			
	SS-CGA640-3-VM	3"			1/4" FSR Male			
	SS-CGA640-3-SET	3"			1/4" NPT Male			
	SS-CGA640-2.5-TW-SET	2.5"			1/4" Tube Weld			
	SS-CGA640-3-VM-SET	3"			1/4" FSR Male			
CGA 642	SS-CGA642-3	3"	1-1/8"	1.030-14NGO-RH	1/4" NPT Male	NI-G-63	/	适用气体: AsF ₅ , PF ₅ , BF ₃ , SiF ₄ , GeF ₄
	SS-CGA642-2.5-TW	2.5"			1/4" Tube Weld			
	SS-CGA642-3-VM	3"			1/4" FSR Male			
	SS-CGA642-3-SET	3"			1/4" NPT Male			
	SS-CGA642-2.5-TW-SET	2.5"			1/4" Tube Weld			
	SS-CGA642-3-VM-SET	3"			1/4" FSR Male			

DISS(UHP) CGA CONNECTIONS

DISS(UHP) CGA 接头

Solutions for Life



接头标准号 Standard No.	接头型号 Model No.	接管长度 L1 Nipple Length	螺帽长度 L2 Nut Length	进口连接 (钢瓶端) Nut Screw	出口连接 Outlet Connection	垫片 Washer	堵帽 Cap	适用气体, 压力 Gases, Pressure
CGA 712	SS-CGA712-3	3"	1-1/8"	1.125-14NGO-RH	1/4" NPT Male	NI-G-63	/	适用气体: N2O 最高工作压力: 3000 psig (20 680 kPa)
	SS-CGA712-2.5-TW	2.5"			1/4" Tube Weld			
	SS-CGA712-3-VM	3"			1/4" FSR Male			
	SS-CGA712-3-SET	3"			1/4" NPT Male			
	SS-CGA712-2.5-TW-SET	2.5"			1/4" Tube Weld			
	SS-CGA712-3-VM-SET	3"			1/4" FSR Male			
CGA 714	SS-CGA714-3	3"	1-1/8"	1.125-14NGO-RH	1/4" NPT Male	NI-G-63	/	适用气体: O2 最高工作压力: 3000 psig (20 680 kPa)
	SS-CGA714-2.5-TW	2.5"			1/4" Tube Weld			
	SS-CGA714-3-VM	3"			1/4" FSR Male			
	SS-CGA714-3-SET	3"			1/4" NPT Male			
	SS-CGA714-2.5-TW-SET	2.5"			1/4" Tube Weld			
	SS-CGA714-3-VM-SET	3"			1/4" FSR Male			
CGA 716	SS-CGA716-3	3"	1-1/8"	1.125-14NGO-RH	1/4" NPT Male	NI-G-63	/	适用气体: CO2, SF6, CHF3, C3F8 最高工作压力: 3000 psig (20 680 kPa)
	SS-CGA716-2.5-TW	2.5"			1/4" Tube Weld			
	SS-CGA716-3-VM	3"			1/4" FSR Male			
	SS-CGA716-3-SET	3"			1/4" NPT Male			
	SS-CGA716-2.5-TW-SET	2.5"			1/4" Tube Weld			
	SS-CGA716-3-VM-SET	3"			1/4" FSR Male			
CGA 718	SS-CGA718-3	3"	1-1/8"	1.125-14NGO-RH	1/4" NPT Male	NI-G-63	/	适用气体: Ar, Kr, N, He, Ne, Xe 最高工作压力: 3000 psig (20 680 kPa)
	SS-CGA718-2.5-TW	2.5"			1/4" Tube Weld			
	SS-CGA718-3-VM	3"			1/4" FSR Male			
	SS-CGA718-3-SET	3"			1/4" NPT Male			
	SS-CGA718-2.5-TW-SET	2.5"			1/4" Tube Weld			
	SS-CGA718-3-VM-SET	3"			1/4" FSR Male			
CGA 720	SS-CGA720-3	3"	1-1/8"	1.125-14NGO-RH	1/4" NPT Male	NI-G-63	/	适用气体: NH3 最高工作压力: 3000 psig (20 680 kPa)
	SS-CGA720-2.5-TW	2.5"			1/4" Tube Weld			
	SS-CGA720-3-VM	3"			1/4" FSR Male			
	SS-CGA720-3-SET	3"			1/4" NPT Male			
	SS-CGA720-2.5-TW-SET	2.5"			1/4" Tube Weld			
	SS-CGA720-3-VM-SET	3"			1/4" FSR Male			
CGA722	SS-CGA722-3	3"	1-1/8"	1.125-14NGO-RH	1/4" NPT Male	NI-G-63	/	适用气体: H2S 最高工作压力: 3000 psig (20 680 kPa)
	SS-CGA722-2.5-TW	2.5"			1/4" Tube Weld			
	SS-CGA722-3-VM	3"			1/4" FSR Male			
	SS-CGA722-3-SET	3"			1/4" NPT Male			
	SS-CGA722-2.5-TW-SET	2.5"			1/4" Tube Weld			
	SS-CGA722-3-VM-SET	3"			1/4" FSR Male			

DISS(UHP) CGA CONNECTIONS

Solutions for Life

DISS(UHP) CGA 接头



接头标准号 Standard No.	接头型号 Model No.	接管长度 L1 Nipple Length	螺帽长度 L2 Nut Length	进口连接(钢瓶端) Nut Screw	出口连接 Outlet Connection	垫片 Washer	堵帽 Cap	适用气体, 压力 Gases, Pressure
CGA 724	SS-CGA724-3	3"	1-1/8"	1.125-14NGO-RH	1/4" NPT Male	NI-G-63	/	适用气体: CO, C2H4, CH2F2, D, H, C4H10FO2P, 最高工作压力: 3000 psig (20 680 kPa)
	SS-CGA724-2.5-TW	2.5"			1/4" Tube Weld			
	SS-CGA724-3-VM	3"			1/4" FSR Male			
	SS-CGA724-3-SET	3"			1/4" NPT Male			
	SS-CGA724-2.5-TW-SET	2.5"			1/4" Tube Weld			
	SS-CGA724-3-VM-SET	3"			1/4" FSR Male			
CGA 726	SS-CGA726-3	3"	1-1/8"	1.125-14NGO-RH	1/4" NPT Male	NI-G-63	/	适用气体: C2H5, C2H6Zn, Zn(C2H5)2, C6H15Al 最高工作压力: 3000 psig (20 680 kPa)
	SS-CGA726-2.5-TW	2.5"			1/4" Tube Weld			
	SS-CGA726-3-VM	3"			1/4" FSR Male			
	SS-CGA726-3-SET	3"			1/4" NPT Male			
	SS-CGA726-2.5-TW-SET	2.5"			1/4" Tube Weld			
	SS-CGA726-3-VM-SET	3"			1/4" FSR Male			
CGA 728	SS-CGA728-3	3"	1-1/8"	1.125-14NGO-RH	1/4" NPT Male	NI-G-63	/	适用气体: Cl, F, NO, ClF3 最高工作压力: 3000 psig (20 680 kPa)
	SS-CGA728-2.5-TW	2.5"			1/4" Tube Weld			
	SS-CGA728-3-VM	3"			1/4" FSR Male			
	SS-CGA728-3-SET	3"			1/4" NPT Male			
	SS-CGA728-2.5-TW-SET	2.5"			1/4" Tube Weld			
	SS-CGA728-3-VM-SET	3"			1/4" FSR Male			

CGA CONNECTIONS

医用气体用接瓶架式CGA 接头

Solutions for Life

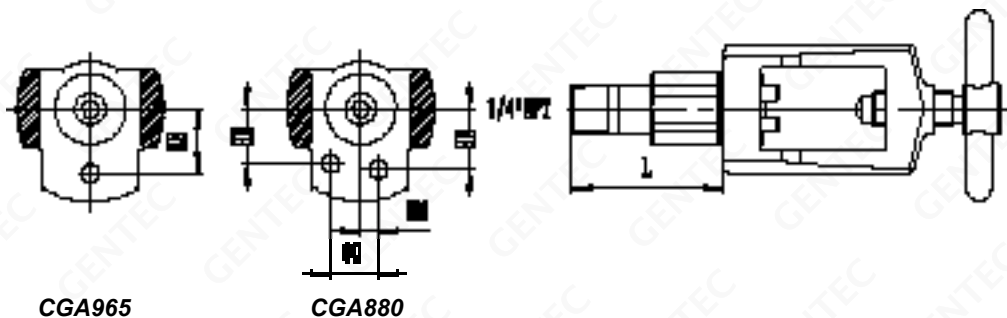

接头标准号 Standard No.	接头型号 Model No.	材料 Material	接管长度 L1 Nipple Length	进口连接(钢瓶端) Nut Screw	出口连接 Outlet Connection	垫片 Washer	适用气体, 压力 Gases, Pressure
CGA 870	BP-CGA870-STD	黄铜电镀	1-1/8"	Yoke		Neoprene	适用气体: O2 最高工作压力: 3000 psig (20 680 kPa)
	BP-CGA870-2		2"				
	BP-CGA870-3		2-1/2"				
CGA 880*	BP-CGA880-STD	黄铜电镀	1-1/8"	Yoke		Neoprene	适用气体: O2 和 CO2 的混合气 最高工作压力: 3000 psig (20 680 kPa)
	BP-CGA880-2		2"				
	BP-CGA880-3		2-1/2"				
CGA 890*	BP-CGA890-STD	黄铜电镀	1-1/8"	Yoke		Neoprene	适用气体: He 和 O2 的混合气 N2 和 O2 的混合气 Xe 和 O2 的混合气 最高工作压力: 3000 psig (20 680 kPa)
	BP-CGA890-2		2"				
	BP-CGA890-3		2-1/2"				
CGA 900*	BP-CGA900-STD	黄铜电镀	1-1/8"	Yoke		Neoprene	适用气体: C2H4 最高工作压力: 3000 psig (20 680 kPa)
	BP-CGA900-2		2"				
	BP-CGA900-3		2-1/2"				
CGA 910*	BP-CGA910-STD	黄铜电镀	1-1/8"	Yoke		Neoprene	适用气体: N2O 最高工作压力: 3000 psig (20 680 kPa)
	BP-CGA910-2		2"				
	BP-CGA910-3		2-1/2"				
CGA 920*	BP-CGA920-STD	黄铜电镀	1-1/8"	Yoke		Neoprene	适用气体: C3H6 最高工作压力: 500 psig (3450 kPa)
	BP-CGA920-2		2"				
	BP-CGA920-3		2-1/2"				
CGA 930*	BP-CGA930-STD	黄铜电镀	1-1/8"	Yoke		Neoprene	适用气体: He, He 和 O2 的混合气 最高工作压力: 3000 psig (20 680 kPa)
	BP-CGA930-2		2"				
	BP-CGA930-3		2-1/2"				
CGA 940*	BP-CGA940-STD	黄铜电镀	1-1/8"	Yoke		Neoprene	适用气体: CO2 及其混合气 最高工作压力: 3000 psig (20 680 kPa)
	BP-CGA940-2		2"				
	BP-CGA940-3		2-1/2"				
CGA 950*	BP-CGA950-STD	黄铜电镀	1-1/8"	Yoke		Neoprene	适用气体: Air 最高工作压力: 3000 psig (20 680 kPa)
	BP-CGA950-2		2"				
	BP-CGA950-3		2-1/2"				
CGA 960*	BP-CGA960-STD	黄铜电镀	1-1/8"	Yoke		Neoprene	适用气体: N2 最高工作压力: 3000 psig (20 680 kPa)
	BP-CGA960-2		2"				
	BP-CGA960-3		2-1/2"				
CGA 965	BP-CGA965-STD	黄铜电镀	1-1/8"	Yoke		Neoprene	适用气体: N2O 和 O2 混合气 最高工作压力: 3000 psig (20 680 kPa)
	BP-CGA965-2		2"				
	BP-CGA965-3		2-1/2"				
CGA 973*	BP-CGA973-STD	黄铜电镀	1-1/8"	Yoke		Neoprene	适用气体: 其它未指定接头的非可燃、非腐蚀性医用混合气 最高工作压力: 3000 psig (20 680 kPa)
	BP-CGA973-2		2"				
	BP-CGA973-3		2-1/2"				

*未备库存

**此项仅供参考, 实际使用时还需仔细确认, 尤其是混合气比例。

气体 Gases	CGA 接头号 CGA No.	UHP CGA 接头号 UHP CGA No.	DIN 接头号 DIN No.	JIS 接头号 JIS No.
乙炔 Acetylene	510	/	/	/
空气 Air	346	/	/	/
氨气 Ammonia	705	720	DIN 6	22-R
氩气 Argon	580	718	DIN 6	22-4 or 23-R
砷化氢 AsH3	350	632	/	22-L
三氯化硼 Boron Trichloride	660	634	DIN 8	/
三氟化硼 Boron Trifluoride	330	642	DIN 8	22-L
丁烷, 瓦斯 Butane	510	/	/	/
二氧化碳 Carbon Dioxide	320	716	DIN 6	/
一氧化碳 Carbon Monoxide	350	724	DIN 5	22-L
环丙烷 Cyclopropane	510	/	/	/
乙硼烷 B2H6	350	632	/	22-L
二氯甲硅烷 DichloroSiH4	678	636	DIN 5	/
二乙基锌 Diethylzinc	510	726	/	/
乙烷 Ethane	350	/	/	/
氯乙烷 Ethyl Chloride	510	/	/	/
乙烯 Ethylene	350	/	/	/
环氧乙烷 Ethylene Oxide	510	/	/	/
锗烷 GeH4	350 or 660	632	/	/
Halocarbon 11 (116)	660	716	/	/
Halocarbon 12 (13,23,115)	660	716	DIN 6	
Halocarbon 14	320 or 580	716	DIN 6	/
氦气 Helium	580	718	DIN 6	22-R or 23-R
氢气 Hydrogen	350	724	DIN 1	22-L
氯化氢 Hydrogen Chloride	330	634	DIN 8	26-R
氟化氢 Hydrogen Fluoride	660 or 670	638	/	26-R
硫化氢 Hydrogen Sulfide	330	722	DIN 5	/
异丁烷 Iso-Butane	510	/	/	/
氙 Krypton	580	718	DIN 6	22-R or 23-R
甲烷 Methane	350	/	/	/
氯甲烷 Methyl Chloride	660	/	/	/
天然气 Natural Gas	350	/	/	/
氖气 Neon	580	718	DIN 6	22-R or 23-R
一氧化氮 Nitric Oxide	660	/	/	/
氮气 Nitrogen	580	718	DIN 10	22-R or 23-R
三氯化氮 Nitrogen Trifluoride	330 or 670	640	DIN 8	/
笑气 Nitrous Oxide	326	712	DIN 8	/
氧气 Oxygen	540	714	DIN 9	22-R or 23-R
磷化氢 Phosphine	350	632	DIN 1	/
丙烷 Propane	510	/	/	/
硅甲烷 SiH4	350	632	/	/
四氯化硅 Silicon Tetrachloride	330	636	/	/
四氟化硅 Silicon Tetrafluoride	330	642	/	22-L
六氟化硫 Sulfur Hexafluoride	590	716	DIN 6	26-R
六氟化钨 Tungsten Hexafluoride	670	638	DIN 8	/
氙气 Xenon	580	718	DIN 6	22-R

* 此表仅供参考



北京办事处（华北地区）

电话：010-65579420

传真：010-65578994

地址：北京市丰台区顺三条21号2号楼
嘉业大厦12A10室

青岛办事处（山东地区）

电话：0532-66776940

传真：0532-66776941

地址：青岛市市南区福州南路19号
3号楼2404室

西安办事处（西北地区）

电话：029-88216277

传真：029-88216277

地址：西安市雁塔区南二环西段154号
易和蓝钻办公楼一单元10层04室

成都办事处（西南地区）

电话：028-85085744

传真：028-85081044

地址：成都市武侯区鞋都南一路9号
鞋王大厦C栋1403室

广州办事处（华南地区）

电话：020-85207471

传真：020-85207692

地址：广州市白云大道北770号
汇金广场C座1403室

武汉办事处（华中地区）

电话：027-88121829

传真：027-88122039

地址：武汉市武昌区和平大道666号
融侨华府1栋2单元501室



捷锐企业（上海）有限公司

GENTEC (SHANGHAI) CORPORATION

上海市松江区玉树路1988号, 201699

电话：021-67727722

传真：021-67727754

网址：www.gentec.com

电子邮件：info@gentec.com.cn



Genstar Technologies Company Inc.

4525 Edison Avenue, Chino, CA 91710, USA

Tel: 909-606-2726

Fax: 909-606-6485

www.gentec.com